

Please fill in the below information as complete as possible to quickly receive the most accurate quote possible.

*Standard JCP tolerances are shown. If tighter tolerance required please note on drawing or "Comments" section below.

Company Name:

Date:

Company Type: Distributor

End User

Sales Rep:

Quoting Contact Name:

Email:

Technical Contact (if possible):

Email:

Phone:

Fax:

Preferred contact method:

Email

Phone

Fax

If **NEW** customer please fill out below:

*An account application will be emailed

Requesting terms account? :

Yes*

No

Later

* All orders will be cc until terms are approved

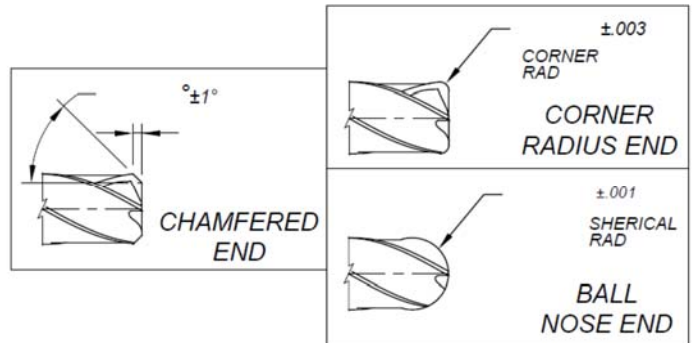
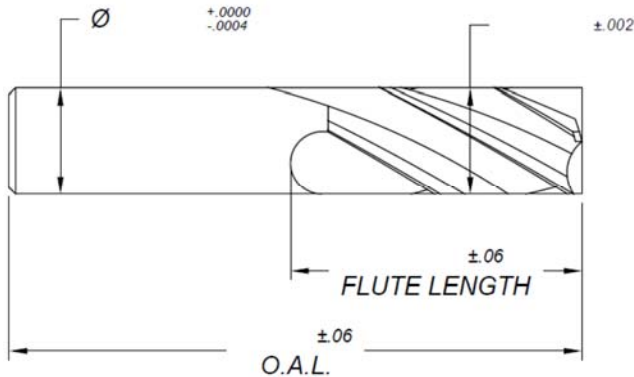

Tool No:

JCP assigned

Material to be cut:

JCP* *indicates JCP recommendation / standard

of flutes:

Flute configuraion:

Helical

Straight

Coating:

Quote with and without

Coolant fed:

Yes

No

Quote with and without

Quantities to quote:

Comments: (issues with current tool, areas of concern, delivery target, cost target, etc.)